

**UNIVERSITY OF BOLTON**

**SCHOOL OF THE BUILT ENVIRONMENT &  
ENGINEERING – RAK CAMPUS**

**BSc(HONS) CIVIL ENGINEERING**

**SEMESTER THREE EXAMINATION 2010/2011**

**STRUCTURES**

**MODULE NO: BLT3019**

Date: Wednesday 31 August 2011

Time: 1.00 pm – 3.00 pm

---

**INSTRUCTIONS TO CANDIDATES:**

There are **FOUR** questions.

Answer **THREE** questions.

All questions carry equal marks.

Total 75 marks for the paper.

Marks for parts of questions are shown in brackets.

Extracts from EC3 to be used with Question 2 are included with this paper.

---

School of the Built Environment & Engineering – RAK Campus  
 BSc(Hons) Civil Engineering  
 Semester Three Examination 2010/2011  
 Structures  
 Module No. BLT3019

**Question 1**

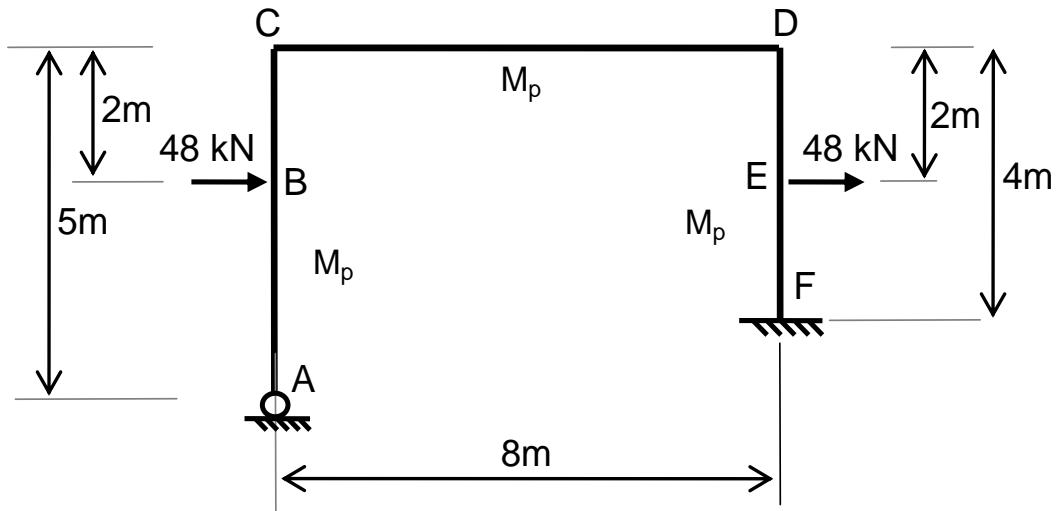

**Figure Q1**

Figure Q1 shows a rigid-jointed frame ABCDEF pinned to a support at A and fixed to a support at F. The plastic moment of resistance  $M_p$  is constant throughout.

The frame carries two horizontal loads of 48 kN as shown.

- a. Find the values of  $M_p$  which correspond to the following collapse mechanisms:
- Plastic hinges at B and C.
  - Plastic hinges at D, E and F
  - Plastic hinges at C, D and F

(13 marks)

- b. Draw the bending moment diagram for the most critical of the collapse mechanisms in part (a), showing values at A, B, C, D, E and F

(9 marks)

- c. Explain how the results of (a) and (b) indicate another, more critical, mechanism. Sketch this mechanism.

(3 marks)

**Total 25 marks**

**Please turn the page**

School of the Built Environment & Engineering – RAK Campus  
 BSc(Hons) Civil Engineering  
 Semester Three Examination 2010/2011  
 Structures  
 Module No. BLT3019

**Question 2**

1. Explain the difference between a short, *stocky* column and a long, *slender* column failure. (5 marks)

2. A multi-storey building requires an internal steel column which will carry an ultimate design axial compressive load of 2400 kN. The column has pinned boundary conditions at each end, and the inter-storey height is 5 m.

Two alternatives are proposed:

- i) A circular hollow section with a diameter 273 mm and wall thickness of 12.5 mm as shown in Figure Q2(a).
- ii) Hot rolled UKC 254x254x107 section as shown in Figure Q2(b).

(a) By using the EC3 method, assess the suitability of both alternatives to resist the ultimate design axial compressive load. (17 marks)

(b) What conclusion do you draw from the results in part (a)?

Which section shape do you recommend and why? (3 marks)

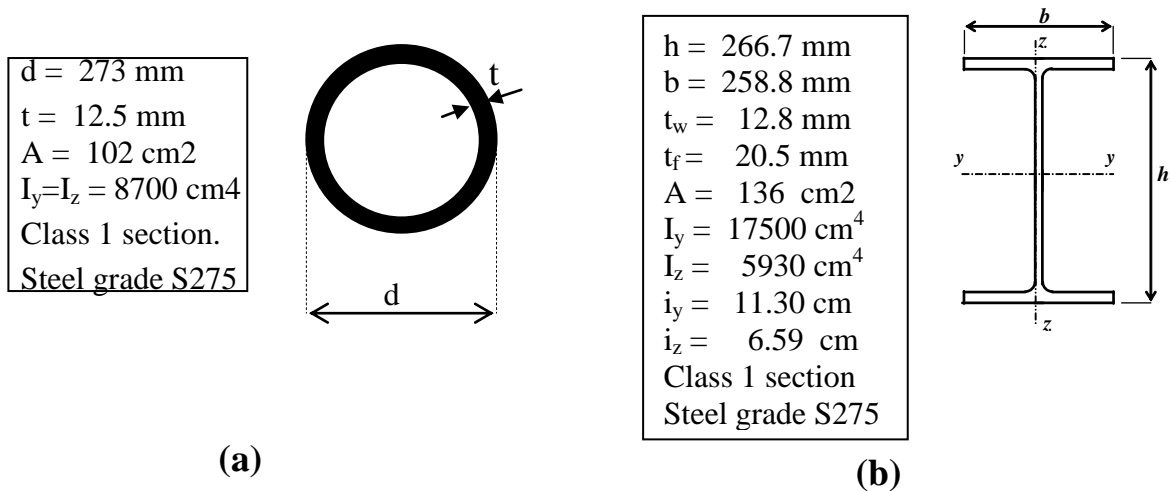

Figure Q2

Total 25 marks

Question 2 continued over the page...

School of the Built Environment & Engineering – RAK Campus  
BSc(Hons) Civil Engineering  
Semester Three Examination 2010/2011  
Structures  
Module No. BLT3019

**Question 2 continued**

**Additional information:**

Euler critical load  $N_{cr} = \frac{\pi^2 EI}{l_{cr}^2}$

Modulus of Elasticity  $E = 210 \text{ kN/mm}^2$   
Yield strength  $f_y = 275 \text{ N/mm}^2$

**Extracts from EC3 to be used with Question 2 are included with this paper.**

**Please turn the page**

School of the Built Environment & Engineering – RAK Campus  
 BSc(Hons) Civil Engineering  
 Semester Three Examination 2010/2011  
 Structures  
 Module No. BLT3019

**Question 3****Figure Q3**

Figure Q3 shows a pre-stressed concrete beam. The beam contains seven pre-stressing strands (12.9mm diameter, 7 wire super strand) at a height of 150mm from the bottom of the beam.

The beam supports dwellings and so the proportion of the variable load to be considered in the quasi permanent loading condition is 0.3. In service, the beam is simply supported over a span of 7.0m and carries the following loads:

Permanent load (including beam self-weight)	60 kN/m
Variable load	40 kN/m

Characteristic breaking load of one strand	= 186 kN
Initial pre-stress	= 70% of UTS
Pre-stress losses	= 25% of initial pre-stress
Concrete strength at transfer	$f_{ck} = 35 \text{ N/mm}^2$
Concrete strength in service	$f_{ck} = 45 \text{ N/mm}^2$
For the whole concrete section:	Area = $412.5 \times 10^3 \text{ mm}^2$
	$I_{NA} = 15.8 \times 10^9 \text{ mm}^4$

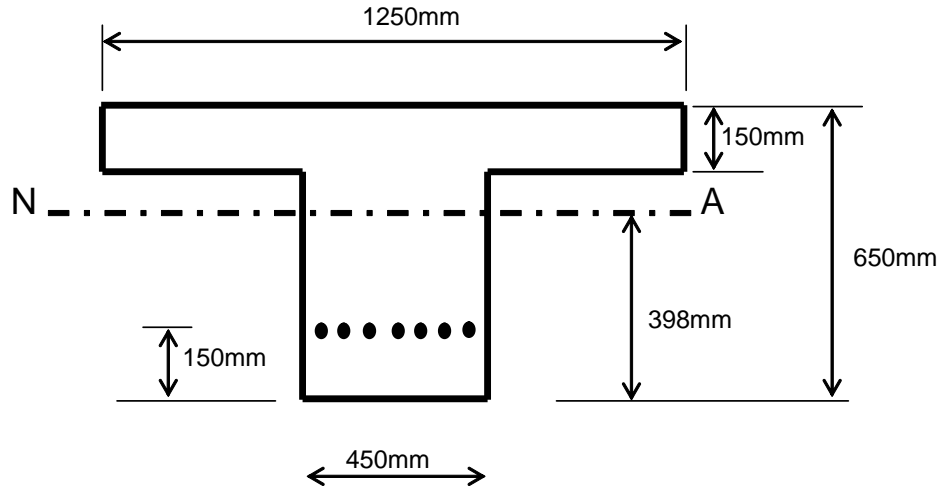
Limiting stresses in concrete:

At transfer	$0.6 f_{ck}$ in compression;	$1 \text{ N/mm}^2$ in tension
In service	$0.45 f_{ck}$ in compression;	$3.8 \text{ N/mm}^2$ in tension

(a) Compare the advantages and disadvantages of bonded and unbonded pre-stressed concrete construction

(4 marks)

**Question 3 continued over the page...**

School of the Built Environment & Engineering – RAK Campus  
BSc(Hons) Civil Engineering  
Semester Three Examination 2010/2011  
Structures  
Module No. BLT3019

**Question 3 continued**

- (b) Calculate the stresses in the concrete at the top and bottom of the beam: (i) at transfer; (ii) in service under quasi-permanent loads  
(12 marks)
- (c) Draw the distribution of stress over the height of the beam: (i) at transfer; (ii) in service under quasi-permanent loads  
(4 marks)
- (d) Compare the calculated values of stress in the concrete with the limiting values of stress in the concrete: (i) at transfer; (ii) in service under quasi-permanent loads  
(3 marks)
- (e) Comment on the adequacy of the beam. Suggest two ways to improve the capacity of the beam  
(2 marks)

**Total 25 marks**

**Please turn the page**

School of the Built Environment & Engineering – RAK Campus  
BSc(Hons) Civil Engineering  
Semester Three Examination 2010/2011  
Structures  
Module No. BLT3019

**Question 4**

The L shaped bracket shown in the Figures Q4 (a) and Q4 (b) is connected to a steel column 410mm deep with 8 M20 grade 8.8 bolts. The shear capacity of one bolt is 91.9kN; the tensile capacity of one bolt is 110kN. The bracket is formed from UB409 x 178 x 74 kg/m steel section with the following properties:

Web thickness	9.7mm
Flange thickness	16mm
Depth of section	413mm
Width of section	180mm

A factored vertical force of 80kN is applied at the location shown in the plan view of the bracket..

(i) What is the out of plane moment in the bolt group?

(2 marks)

(ii) What is the in plane moment in the bolt group?

(2 marks)

(iii) What are the tension and shear forces in the two bolts in bolt row b1?

(15 marks)

(iv) Comment on the adequacy of the specified bolts.

(2 marks)

(v) What further checks should be carried out to confirm the adequacy of this connection?

(4 marks)

**Total 25 marks**

**Question 4 continued over the page...**

School of the Built Environment & Engineering – RAK Campus  
 BSc(Hons) Civil Engineering  
 Semester Three Examination 2010/2011  
 Structures  
 Module No. BLT3019

**Question 4 continued**

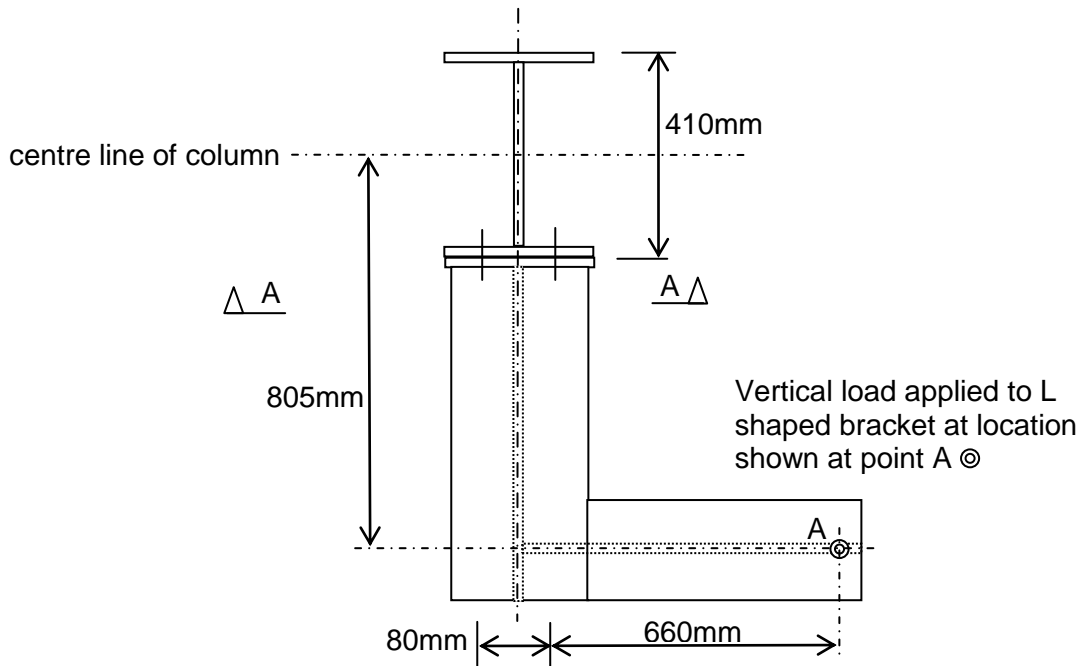

**Figure Q4 (a)**  
 PLAN VIEW ON BRACKET

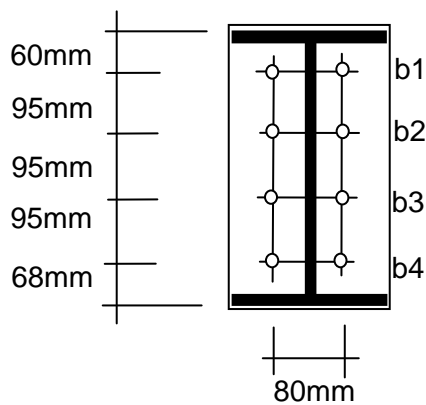

**Figure Q4 (b)**  
 SECTIONAL ELEVATION A-A ON BOLTED ENDPLATE  
 SHOWING SETTING OUT OF BOLTS

**END OF QUESTIONS**

## DATA SHEET TO BE USED WITH QUESTION 2

Extracts from Eurocode 3: Design of steel structures

### 6.3 Buckling resistance of members

#### 6.3.1 Uniform members in compression

##### 6.3.1.1 Buckling resistance

(1) A compression member shall be verified against buckling as follows:

$$\frac{N_{Ed}}{N_{b,Rd}} \leq 1,0 \quad (6.46)$$

where

$N_{Ed}$  is the design value of the compression force  
 $N_{b,Rd}$  is the design buckling resistance of the compression member.

(3) The design buckling resistance of a compression member should be taken as:

$$N_{b,Rd} = \frac{\chi A f_y}{\gamma_{M1}} \quad \text{for Class 1, 2 and 3 cross-sections} \quad (6.47)$$

$$N_{b,Rd} = \frac{\chi A_{eff} f_y}{\gamma_{M1}} \quad \text{for Class 4 cross-sections} \quad (6.48)$$

where  $\chi$  is the reduction factor for the relevant buckling mode.

NOTE For determining the buckling resistance of members with tapered sections along the member or for non-uniform distribution of the compression force second-order analysis according to 5.3.4(2) may be performed. For out-of-plane buckling see also 6.3.4.

(4) In determining  $A$  and  $A_{eff}$  holes for fasteners at the column ends need not to be taken into account.

##### 6.3.1.2 Buckling curves

(1) For axial compression in members the value of  $\chi$  for the appropriate non-dimensional slenderness  $\bar{\lambda}$  should be determined from the relevant buckling curve according to:

$$\chi = \frac{1}{\phi + \sqrt{\phi^2 - \bar{\lambda}^2}} \quad \text{but } \chi \leq 1,0 \quad (6.49)$$

where  $\phi = 0,5 [1 + \alpha (\bar{\lambda} - 0,2) + \bar{\lambda}^2]$

$$\bar{\lambda} = \sqrt{\frac{A f_y}{N_{cr}}} \quad \text{for Class 1, 2 and 3 cross-sections}$$

$$\bar{\lambda} = \sqrt{\frac{A_{eff} f_y}{N_{cr}}} \quad \text{for Class 4 cross-sections}$$

$\alpha$  is an imperfection factor

$N_{cr}$  is the elastic critical force for the relevant buckling mode based on the gross cross sectional properties.

(2) The imperfection factor  $\alpha$  corresponding to the appropriate buckling curve should be obtained from Table 6.1 and Table 6.2.

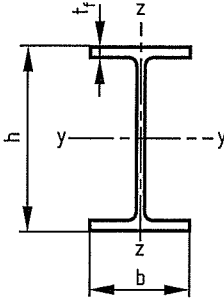
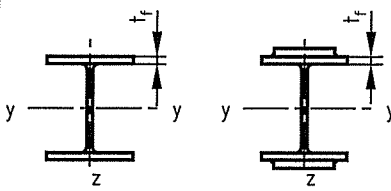

**Table 6.1 – Imperfection factors for buckling curves**

Buckling curve	$a_0$	$a$	$b$	$c$	$d$
Imperfection factor $\alpha$	0,13	0,21	0,34	0,49	0,76

(3) Values of the reduction factor  $\chi$  for the appropriate non-dimensional slenderness  $\bar{\lambda}$  may be obtained from Figure 6.4.

(4) For slenderness  $\bar{\lambda} \leq 0,2$  or for  $\frac{N_{Ed}}{N_{cr}} \leq 0,04$  the buckling effects may be ignored and only cross-sectional checks apply.

Table 6.2 – Selection of buckling curve for a cross-section

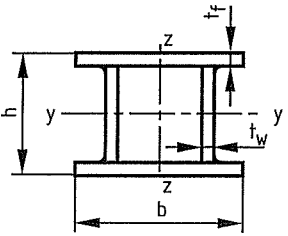
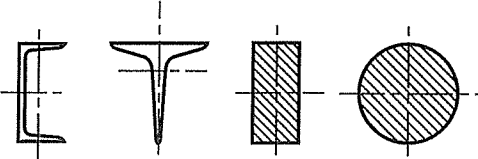
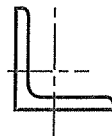
Cross section		Limits		Buckling about axis	Buckling curve	
					S 235 S 275 S 355 S 420	S 460
Rolled sections		$h/b > 1,2$	$t_f \leq 40 \text{ mm}$	y - y z - z	a b	a <sub>0</sub> a <sub>0</sub>
			$40 \text{ mm} < t_f \leq 100$	y - y z - z	b c	a a
		$h/b \leq 1,2$	$t_f \leq 100 \text{ mm}$	y - y z - z	b c	a a
			$t_f > 100 \text{ mm}$	y - y z - z	d d	c c
Welded I sections		$t_f \leq 40 \text{ mm}$		y - y z - z	b c	b c
		$t_f > 40 \text{ mm}$		y - y z - z	c d	c d
Hollow sections		hot finished		any	a	a <sub>0</sub>
		cold formed		any	c	c
Welded box sections		generally (except as below)		any	b	b
		thick welds: $a > 0,5t_f$ $b/t_f < 30$ $h/t_w < 30$		any	c	c
U, T and solid sections				any	c	c
L sections				any	b	b