

UNIVERSITY OF BOLTON
**SCHOOL OF THE BUILT ENVIRONMENT &
ENGINEERING – RAK CAMPUS**
BSc(HONS) CIVIL ENGINEERING
SEMESTER ONE EXAMINATION 2010/2011
STRUCTURAL ANALYSIS
MODULE NO: BLT1014

Date: Monday 24 January 2011

Time: 2.00 pm – 4.00 pm

INSTRUCTIONS TO CANDIDATES:

There are **FOUR** questions.

Answer **THREE OF THE FOUR** questions.

All questions carry equal marks.

Marks for parts of questions are shown in brackets.

This examination paper carries a total of 75 marks.

All working must be shown. A numerical solution to a question obtained by programming an electronic calculator will not be accepted.

School of the Built Environment & Engineering – RAK Campus
 BSc(Hons) Civil Engineering
 Semester One Examination 2010/2011
 Structural Analysis
 Module No. BLT1014

Question 1

Figure Q1 below shows a simply supported beam ABCDE, which is supported at B and D, with overhanging portions, AB and DE. The beam carries a partial UDL of 30 kN/m between D and E, a vertical point load of 15 kN at A and a vertical point load of 40 kN at C, as shown in Figure Q1.

For the beam:

- Determine the value and direction of the support reactions at B and D. (5 marks)
- Draw the Shear Force diagram. Show the values of shear force at A, B, C, D, and E along the beam and indicate the points along the beam where high values of bending moment will occur. (8 marks)
- Draw the Bending Moment diagram, indicating the values of bending moment at significant points along the beam. (10 marks)
- State the value of the maximum bending moment and its position along the beam. (2 marks)

Total 25 marks

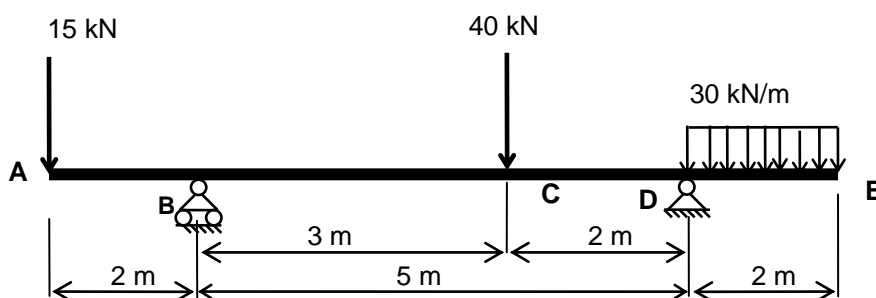

FIGURE Q1

Please turn the page

School of the Built Environment & Engineering – RAK Campus
 BSc(Hons) Civil Engineering
 Semester One Examination 2010/2011
 Structural Analysis
 Module No. BLT1014

Question 2

Figure Q2 shows a pin jointed truss, with a pin support at A and a roller support at F. The truss is subjected to three vertical loads: 30 kN at joint C, 20 kN at joint D and 40 kN at joint G.

- Use the formula $(m + r - 2j = 0)$ to demonstrate that the truss is statically determinate. (2 marks)
- Determine the values of the three support reactions at supports A and F. (6 marks)
- Using the Method of Joints, determine the value and type of force in each element of the truss and summarise your answer on a diagram of the truss layout. (17 marks)

Total 25 marks

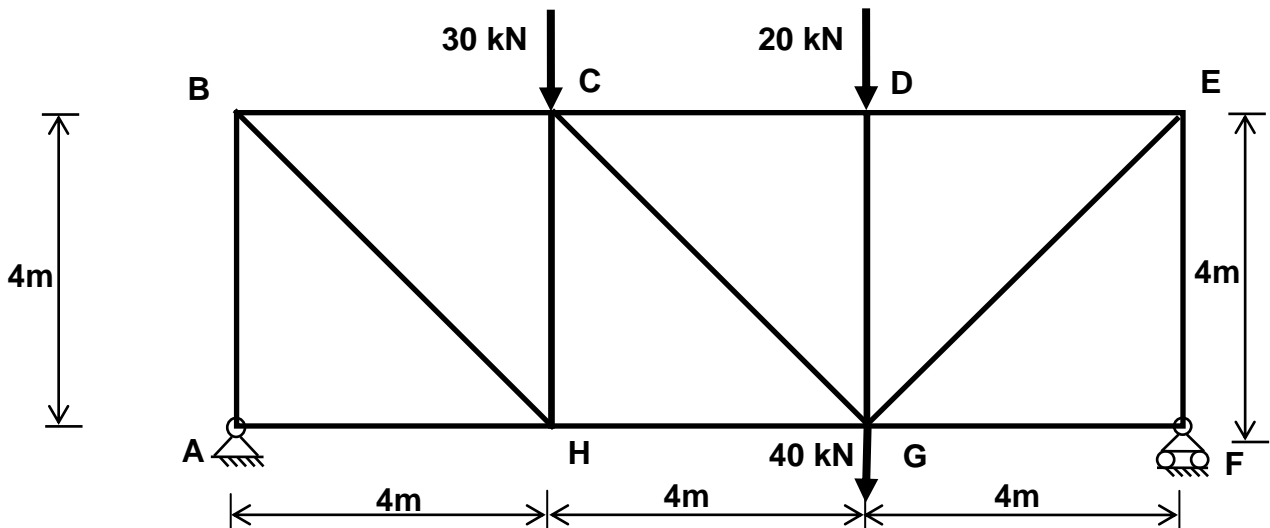

Figure Q2

Please turn the page

School of the Built Environment & Engineering – RAK Campus
 BSc(Hons) Civil Engineering
 Semester One Examination 2010/2011
 Structural Analysis
 Module No. BLT1014

Question 3

Figure Q3 shows a three pin frame, pinned to supports at A and E, with a third pin at C. There is a horizontal point load of 40 kN at position B, and a horizontal point load of 30 kN at position D as shown in Figure Q3.

- Calculate the value of the support reactions at A and E. (5 marks)
- Draw the axial force diagram (AFD) (5 marks)
- Draw the shear force diagram (SFD) (7 marks)
- Draw the bending moment diagram (BMD) (8 marks)

For b), c) and d), show all important values on the diagrams and produce accompanying calculations to show how these values have been derived.

Total 25 marks

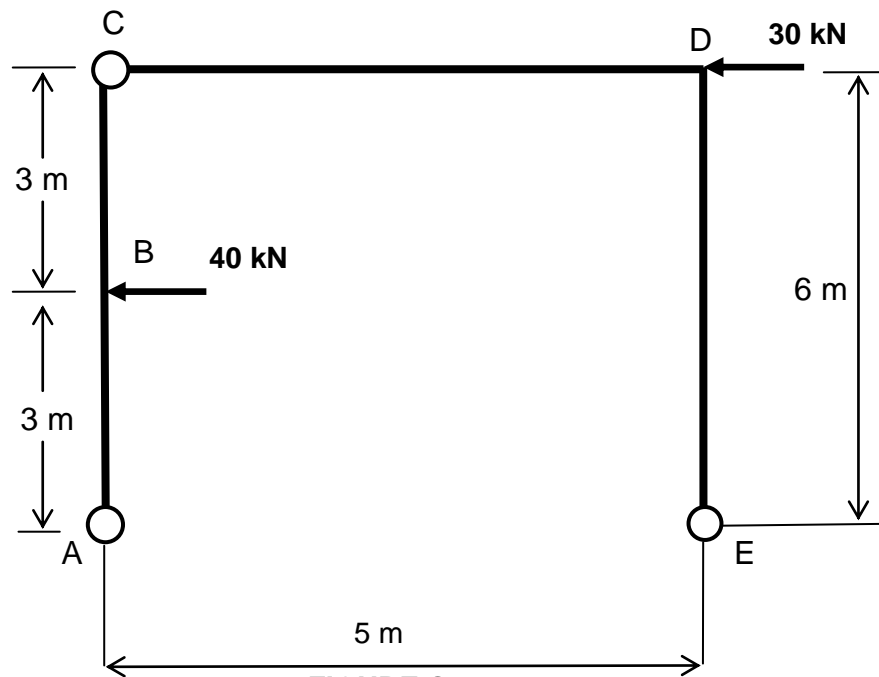

FIGURE Q3

Please turn the page

School of the Built Environment & Engineering – RAK Campus
 BSc(Hons) Civil Engineering
 Semester One Examination 2010/2011
 Structural Analysis
 Module No. BLT1014

Question 4

Figure Q4 shows a cross-section of an asymmetrical steel beam with a cantilever span of 8 m. The allowable bending stress either in tension or compression is 200 N/mm^2 .

- a) Determine the position of the horizontal neutral axis of the beam. (6 marks)
- b) What is the value of the second moment of area I about the horizontal neutral axis of the beam section? (12 marks)
- b) What is the maximum force A that can be applied vertically downward to the cantilever beam without exceeding the allowable bending stress in the beam? (4 marks)
- c) What is the maximum uniformly distributed load (UDL) that can be applied vertically upward to the cantilever beam without exceeding the allowable bending stress in the beam (ignore the point load A)? (3 marks)

Total 25 marks

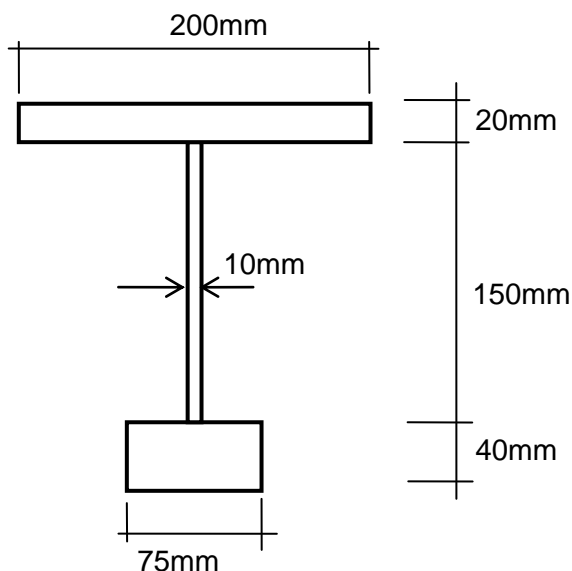

Section through cantilever beam

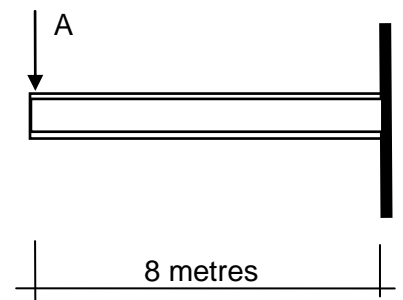

Elevation on cantilever beam

Figure Q4

END OF QUESTIONS