

UNIVERSITY OF BOLTON

**SCHOOL OF THE BUILT ENVIRONMENT &
ENGINEERING – RAK CAMPUS**

BSc (HONS) CIVIL ENGINEERING

SEMESTER TWO EXAMINATION 2009/2010

HYDRAULICS

MODULE NO: BLT 1008

Date: Friday 4 June 2010

Time: 5.00 pm – 7.00 pm

INSTRUCTIONS TO CANDIDATES:

There are **FOUR** questions.

Answer **THREE** questions.

All questions carry equal marks.

Marks for parts of questions are shown in brackets.

A formula sheet and HRS Tables are provided.

School of the Built Environment and Engineering – RAK Campus
 BSc (Hons) Civil Engineering
 Semester Two Examination 2009/2010
 Hydraulics
 Module No. BLT 1008

1. a) Briefly explain what is meant by 'gauge pressure'. If the pressure head in a water main is 50 metres of water, determine the gauge pressure in kN/m^2 . (5 marks)
- b) A rectangular flat plate of mass 140 kg is used as a gate to close an opening in the sloping side of a water tank. The opening and the gate have a width of 700mm and a depth of 950 mm. The gate is hinged at its highest point and is attached to a horizontal lever arm as shown in Figure Q1. The gate is kept closed against the water pressure partly by its own weight acting through its centroid and partly by the mass on the lever arm. Calculate the mass which must be placed on the lever arm so that the gate will open if the water reaches a level of 700 mm above the top of the gate. (Ignore the mass of the lever arm.)

(20 marks)

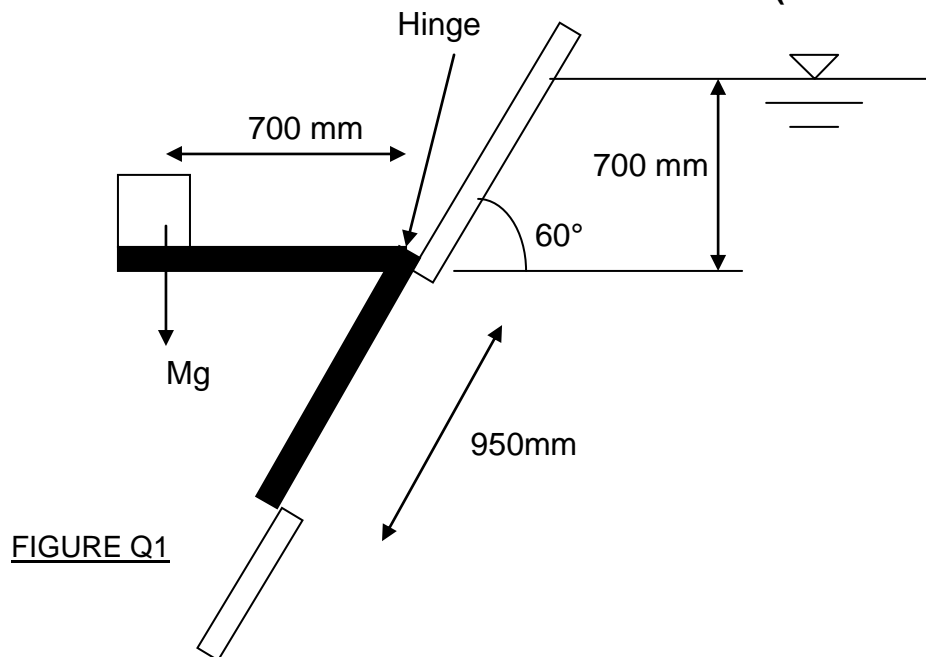
(Total 25 marks)

2. At a desalination plant, sea water flows from a storage tank to a treatment plant. A spun concrete pipe ($\lambda = 0.024$) connecting the tanks is 750 m long, the first 250 m being 450 mm in diameter and the remainder being 300 mm in diameter.

A flow control valve ($K_L = 0.1$ when fully open) is situated in the pipeline, a short distance from the storage tank. The water level in the storage tank is 9.5 m above the water level in the treatment tank.

Question 2 continued over the page...

School of the Built Environment and Engineering – RAK Campus
BSc (Hons) Civil Engineering
Semester Two Examination 2009/2010
Hydraulics
Module No. BLT 1008

4. a) Explain the difference between 'steady uniform flow' and 'steady non-uniform flow' in a rectangular channel. (5 marks)
- b) Determine the flowrate in a 3.5 m wide rectangular channel when the uniform depth of flow is 0.45 m, the Chezy C value is 55 and the channel bed slope is 1 in 600. (6 marks)
- c) A trapezoidal channel has a Manning coefficient of 0.025 and side slopes of 1 vertical = 1.8 horizontal. When the steady uniform flowrate is $1.5 \text{ m}^3/\text{s}$, the depth of flow is 0.9 m and the mean velocity of flow is 0.5 m/s. Determine
- (i) the horizontal base width of the channel. (6 marks)
- (ii) the gradient of the channel bed. (8 marks)

(Total 25 marks)

END OF QUESTIONS

Please turn the page

School of the Built Environment and Engineering – RAK Campus
 BSc (Hons) Civil Engineering
 Semester Two Examination 2009/2010
 Hydraulics
 Module No. BLT 1008

EQUATION SHEET

$$F = \rho g h \bar{A} \quad x_p = \bar{x} + \frac{I_G}{A \bar{x}} \quad I_G = \frac{bd^3}{12}$$

$$Q = V_1 A_1 = V_2 A_2 \quad p = \rho g h$$

$$\frac{P_1}{\rho g} + \frac{v_1^2}{2g} + z_1 = \frac{P_2}{\rho g} + \frac{v_2^2}{2g} + z_2 + \text{energy losses}$$

$$\frac{h_f}{L} = S_o \quad h_f = \frac{\lambda LV^2}{2gd} = \frac{\lambda Q^2}{12.1d^5}$$

$$R = \frac{A}{P} \quad Q = AC\sqrt{RS_o} \quad Q = \frac{A}{n} \cdot R^{2/3} S_o^{1/2}$$

$$H_L = K_L \frac{V^2}{2g} \quad K_{L_{\text{entry}}} = 0.5 \quad K_{L_{\text{cont}}} = \left(\frac{1}{C_c} - 1 \right)^2$$

Please turn the page

School of the Built Environment and Engineering – RAK Campus
 BSc (Hons) Civil Engineering
 Semester Two Examination 2009/2010
 Hydraulics
 Module No. BLT 1008

$k_s = 0.030 \text{ mm}$
 $i = 0.00015 \text{ to } 0.004$

ie hydraulic gradient =
 1 in 6667 to 1 in 250

Water (or sewage) at 15°C
 full bore conditions.

velocities in m/s
 discharges in m^3/s

14

continued

Gradient	Pipe diameters in mm :											
	350	375	400	450	500	525	600	675	700	750	800	825
0.00075 1/ 1333	0.554 0.053	0.580 0.064	0.605 0.076	0.654 0.104	0.700 0.137	0.723 0.156	0.788 0.223	0.850 0.304	0.870 0.335	0.909 0.402	0.947 0.476	0.966 0.516
0.00080 1/ 1250	0.574 0.055	0.601 0.066	0.627 0.079	0.677 0.108	0.725 0.142	0.748 0.162	0.816 0.231	0.880 0.315	0.901 0.347	0.941 0.416	0.981 0.493	1.000 0.535
0.00085 1/ 1176	0.594 0.057	0.621 0.069	0.648 0.081	0.700 0.111	0.749 0.147	0.773 0.167	0.843 0.238	0.909 0.325	0.931 0.358	0.972 0.430	1.013 0.509	1.033 0.552
0.00090 1/ 1111	0.613 0.059	0.641 0.071	0.669 0.084	0.722 0.115	0.773 0.152	0.798 0.173	0.869 0.246	0.938 0.335	0.960 0.369	1.003 0.443	1.045 0.525	1.065 0.570
0.00095 1/ 1053	0.631 0.061	0.660 0.073	0.688 0.087	0.743 0.118	0.796 0.156	0.821 0.178	0.895 0.253	0.965 0.345	0.988 0.380	1.032 0.456	1.076 0.541	1.097 0.586
0.00100 1/ 1000	0.649 0.062	0.679 0.075	0.708 0.089	0.764 0.122	0.818 0.161	0.844 0.183	0.920 0.260	0.992 0.355	1.016 0.391	1.061 0.469	1.106 0.556	1.127 0.603
0.00110 1/ 909	0.683 0.066	0.715 0.079	0.746 0.094	0.805 0.128	0.862 0.169	0.889 0.192	0.969 0.274	1.044 0.374	1.069 0.411	1.117 0.493	1.164 0.585	1.186 0.634
0.00120 1/ 833	0.716 0.069	0.749 0.083	0.782 0.098	0.844 0.134	0.903 0.177	0.932 0.202	1.015 0.287	1.094 0.392	1.120 0.431	1.170 0.517	1.219 0.613	1.243 0.664
0.00130 1/ 769	0.748 0.072	0.783 0.086	0.816 0.103	0.881 0.140	0.943 0.185	0.973 0.211	1.060 0.300	1.142 0.409	1.169 0.450	1.221 0.540	1.272 0.640	1.297 0.694
0.00140 1/ 714	0.779 0.075	0.815 0.090	0.850 0.107	0.917 0.146	0.981 0.193	1.013 0.219	1.103 0.312	1.189 0.425	1.217 0.468	1.271 0.561	1.324 0.665	1.350 0.722
0.00150 1/ 667	0.809 0.078	0.846 0.093	0.882 0.111	0.952 0.151	1.018 0.200	1.051 0.227	1.144 0.324	1.233 0.441	1.262 0.486	1.319 0.583	1.373 0.690	1.400 0.749
0.00160 1/ 625	0.838 0.081	0.876 0.097	0.913 0.115	0.985 0.157	1.054 0.207	1.088 0.236	1.185 0.335	1.277 0.457	1.307 0.503	1.365 0.603	1.422 0.715	1.449 0.775
0.00170 1/ 588	0.865 0.083	0.905 0.100	0.944 0.119	1.018 0.162	1.089 0.214	1.124 0.243	1.224 0.346	1.319 0.472	1.350 0.519	1.410 0.623	1.468 0.738	1.497 0.800
0.00180 1/ 556	0.893 0.086	0.934 0.103	0.973 0.122	1.050 0.167	1.123 0.221	1.159 0.251	1.262 0.357	1.360 0.487	1.391 0.536	1.453 0.642	1.514 0.761	1.543 0.825
0.00190 1/ 526	0.919 0.088	0.961 0.106	1.002 0.126	1.081 0.172	1.157 0.227	1.193 0.258	1.299 0.367	1.400 0.501	1.432 0.551	1.496 0.661	1.558 0.783	1.588 0.849
0.00200 1/ 500	0.945 0.091	0.988 0.109	1.030 0.129	1.111 0.177	1.189 0.233	1.226 0.265	1.335 0.378	1.439 0.515	1.472 0.566	1.537 0.679	1.601 0.805	1.632 0.873
0.00220 1/ 455	0.995 0.096	1.040 0.115	1.084 0.136	1.170 0.186	1.251 0.246	1.291 0.279	1.405 0.397	1.514 0.542	1.549 0.596	1.617 0.715	1.684 0.847	1.717 0.918
0.00240 1/ 417	1.043 0.100	1.090 0.120	1.136 0.143	1.226 0.195	1.311 0.257	1.352 0.293	1.472 0.416	1.585 0.567	1.622 0.624	1.694 0.748	1.764 0.887	1.798 0.961
0.00260 1/ 385	1.089 0.105	1.138 0.126	1.186 0.149	1.279 0.203	1.368 0.269	1.411 0.306	1.536 0.434	1.654 0.592	1.693 0.651	1.768 0.781	1.840 0.925	1.876 1.003
0.00280 1/ 357	1.133 0.109	1.184 0.131	1.235 0.155	1.331 0.212	1.424 0.280	1.468 0.318	1.598 0.452	1.721 0.616	1.761 0.678	1.838 0.812	1.914 0.962	1.951 1.043
0.00300 1/ 333	1.176 0.113	1.229 0.136	1.281 0.161	1.381 0.220	1.477 0.290	1.523 0.330	1.658 0.469	1.785 0.639	1.826 0.703	1.907 0.842	1.985 0.998	2.024 1.082
0.00320 1/ 313	1.217 0.117	1.273 0.141	1.326 0.167	1.430 0.227	1.529 0.300	1.577 0.341	1.715 0.485	1.847 0.661	1.890 0.727	1.973 0.872	2.054 1.033	2.094 1.119
0.00340 1/ 294	1.258 0.121	1.315 0.145	1.370 0.172	1.477 0.235	1.579 0.310	1.628 0.353	1.772 0.501	1.908 0.683	1.952 0.751	2.038 0.900	2.121 1.066	2.162 1.156
0.00360 1/ 278	1.297 0.125	1.355 0.150	1.413 0.178	1.523 0.242	1.628 0.320	1.679 0.363	1.826 0.516	1.966 0.704	2.012 0.774	2.100 0.928	2.186 1.099	2.229 1.191
0.00380 1/ 263	1.335 0.128	1.395 0.154	1.454 0.183	1.567 0.249	1.675 0.329	1.728 0.374	1.879 0.531	2.023 0.724	2.070 0.797	2.161 0.955	2.250 1.131	2.293 1.226
Coefficient for part-full pipes:												
	150	150	150	200	200	250	250	300	300	300	350	350

$k_s = 0.030 \text{ mm}$ $i < 0.004$